

AUTOMATE™

ARC TUBULAR FT MOTOR

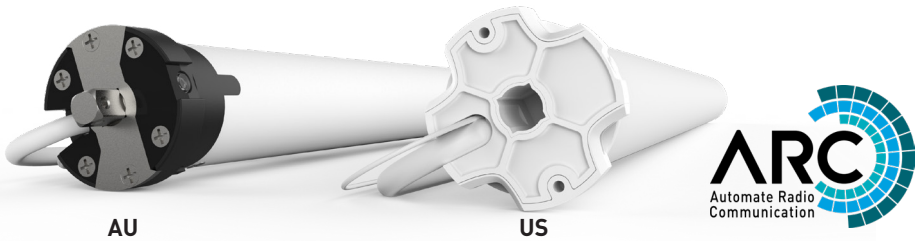

AU

US



433 MHZ
BI-DIRECTIONAL



ELECTRONIC
LIMIT



FAVORITE
POSITION



FABRIC
TENSION



ULTRA
LOCK



IMPACT
DETECTION

AUTOMATE | FT tubular AC motors combine the simple, intuitive features of ARC “Automate Radio Communication” with the higher lifting capacity of an AC motor for larger shade applications. Three alternate modes of operation include:

- E-type for standard use
- MANUAL FT Mode for use with conventional locking devices with fabric tensioning
- AUTO FT Mode for use with Rollease Acmeda’s proprietary ULTRA LOCK providing automatic fabric tensioning

Functional options in each operating mode include: IMPACT DETECTION and FAVORITE POSITION.

- IMPACT DETECTION senses an obstacle in the blinds path during downward movement and redirects the shade to protect the motor, hardware and fabric, ensuring product longevity.
- An intermediate setting allows for a customized FAVORITE POSITION to be preset.

FEATURES:

- Impact Detection (Zipscreen Only)
- High Fabric tension torque
- 433 MHz Bi-Directional RF Communication
- Electronic Limit
- Favorite Position
- Ideal for premium outdoor Zipscreen shade solution
- One action to lock & un-lock shade

CONTENTS

1	ASSEMBLY	4
2	WIRING, MODES & ZONES	5
2.1	AU FT Motor	5
2.2	US FT Motors	5
2.3	Selectable Modes	6
2.4	Impact Detection	6
3	P1 BUTTON FUNCTIONS	7
3.1	Motor state test	7
3.2	Motor configuration options	7
4	INITIAL SET UP	8
4.1	Pair motor with controller	8
4.2	Check motor direction	8
4.3	Set Upper Limit	9
4.4	Set Lower Limit	9
5	ADJUSTING LIMITS	10
5.1	Adjust upper limit	10
5.2	Adjust lower limit	10
6	ADDING OR REMOVING CONTROLLERS AND CHANNELS	11
6.1	Using motor P1 Button to add a new controller or channel	11
6.2	Using a pre-existing controller to add or delete a controller or channel	11
7	FAVORITE POSITIONING	12
7.1	Set a favorite position	12
7.2	Send shade to favorite position	12
7.3	Delete favorite position	12
8	SLEEP MODE	13
9	IMPACT DETECTION MODE	13
10	FT FUNCTION SETTING	14
10.1	Activate / Deactivate Fabric Tension Mode	14
10.2	Switching between Auto & Manual Lock Mode	14
10.3	Auto Mode Operation	15
10.4	Manual Mode Operation	15
11	SUN, WIND AND RAIN SENSOR	16
11.1	Activate/Deactivate Sun, Wind and Rain sensor functionality on the Motor	16
11.2	Pairing Sun, Wind and Rain sensor to Motor	16
12	TROUBLE SHOOTING	17

SAFETY INSTRUCTIONS

WARNING: Important safety instructions to be read before installation.

Incorrect installation can lead to serious injury and will void manufacturer's liability and warranty.

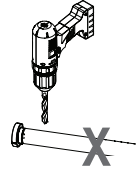
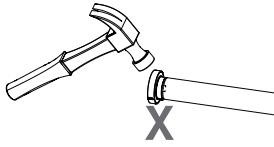

CAUTION

- Do not expose to moisture or extreme temperatures.
- Do not allow children to play with this device.
- Use or modification outside the scope of this instruction manual will void warranty.
- Installation and programming to be performed by a suitably qualified installer.
- For use within tubular blinds.
- Ensure correct crown and drive adaptors are used for the intended system.
- Keep antenna straight and clear from metal objects
- Do not cut the antenna.
- Use only Rollease Acmeda hardware.
- Before installation, remove any unnecessary cords and deactivate any equipment not needed for powered operation.
- Ensure torque and operating time is compatible with end application.
- Do not expose the motor to water or install in humid or damp environments.
- Motor is to be installed in horizontal application only.
- Do not drill into motor body.
- The routing of cable through walls shall be protected by isolating bushes or grommets.
- Ensure power cable and aerial is clear and protected from moving parts.
- If cable or power connector is damaged do not use.

Important safety instructions to be read prior to operation.

- It is important for the safety of persons to follow the enclosed instructions. Save these instructions for future reference.
- Persons (including children) with reduced physical, sensory or mental capabilities, or lack of experience and knowledge should not be allowed to use this product.
- Keep remote controls away from children.
- Frequently inspect for improper operation. Do not use if repair or adjustment is necessary.
- Keep motor away from acid and alkali.
- Do not force the motor drive.
- Keep clear when in operation.



Do not dispose of in general waste.
Please recycle batteries and damaged electrical products appropriately.



1 ASSEMBLY

Please refer to Rollease Acmeda System Assembly Manual for full assembly instructions relevant to the hardware system being used.

Step 1. Cut roller tube to required length.

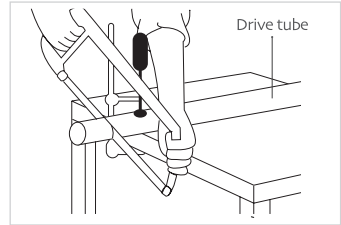

Step 2. Ensure roller tube is clean and free from burrs.



For impact detection to be functional, a 2 piece drive set must be used. Using a standard 1 piece drive will render the collision control feature inoperable even if the feature is turned on.

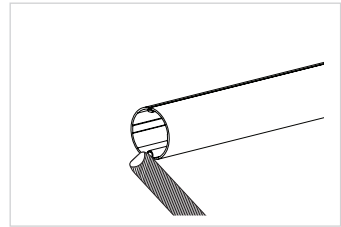

Step 3. Fit required crown, drive and bracket adapters.

Tube must be close fitting with chosen crown and drive adapters. A Hall effect sensor embedded in the tube measures the magnetic field change and detect the impact. Refer to Rollease Acmeda System Assembly Manual for recommended crown, drive and bracket adapter kits.

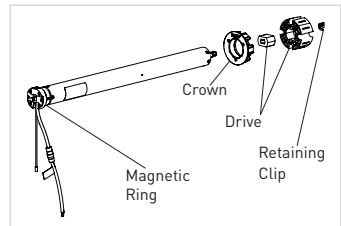

Step 4. Slide Motor into tube.

Insert by aligning key-way in crown and drive wheel into the tube.

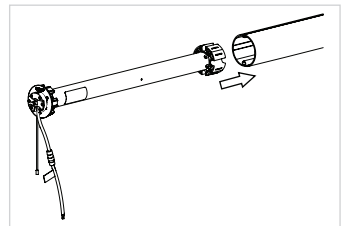

Step 5. Mount motorized tube onto brackets.

Refer to Rollease Acmeda System Assembly Manual for recommended crown, drive and bracket adapter kits.

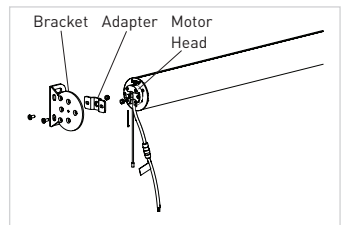

2 WIRING, MODES & ZONES

2.1 AU FT Motor

Disconnect the mains power supply.

Connect the motor according to the information in the table below.



Ensure cable is kept clear of fabric.

Ensure antenna is kept straight and away from metal objects.

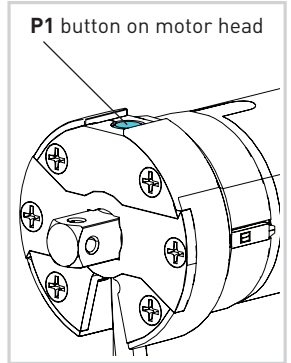
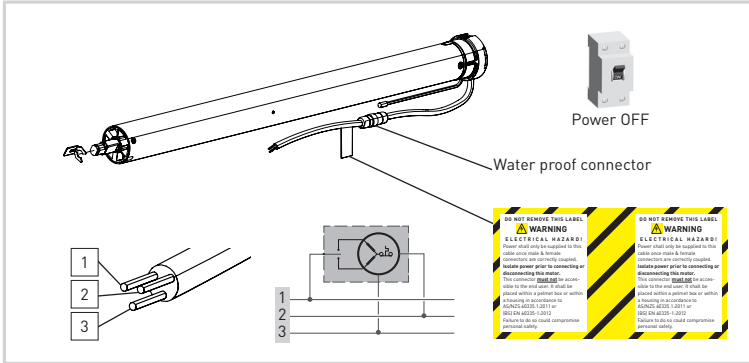

MOTOR	POWER	NEUTRAL	LIVE	EARTH
MT01-1145-050001	220-240V AC 50Hz	Blue	Brown	Yellow/Green

2.2 US FT Motors



Ensure cable is kept clear of fabric.

Ensure antenna is kept straight and away from metal objects.

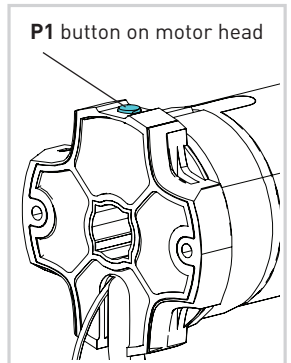
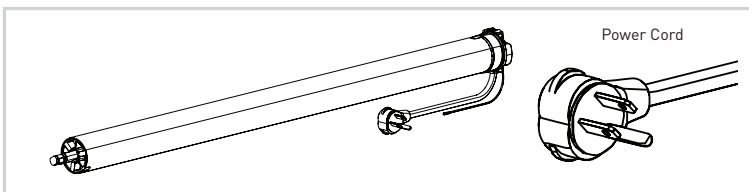

MOTOR	POWER CORD LENGTH	POWER	NEUTRAL	LIVE	EARTH
MT01-1145-069002	118 in. (3000mm)	120 VAC / 60Hz	White	Black	Green
MT01-1145-069003	118 in. (3000mm)				
MT01-1145-069004	240 in. (6096mm)				

2.3 Selectable Modes

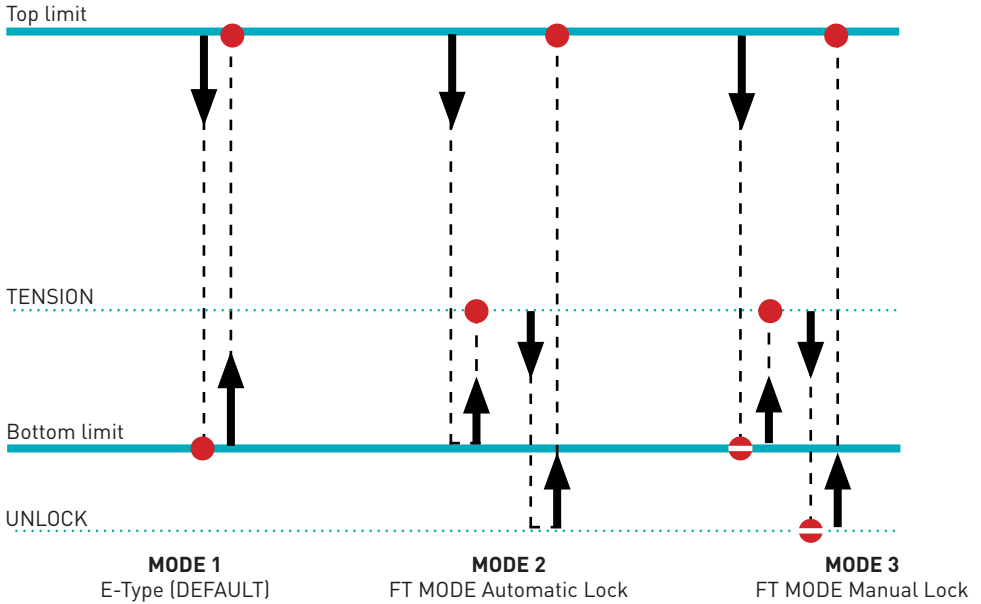

LEGEND

END OF CYCLE ●

CYCLE PAUSE ◐

2.4 Impact Detection

Impact detection is deactivated by default. Impact detection may be activated in all 3 modes. If an obstacle is detected twice in the shade path during downwards movement, the motor lifts the shade up ~ 7.87in. (20cm).

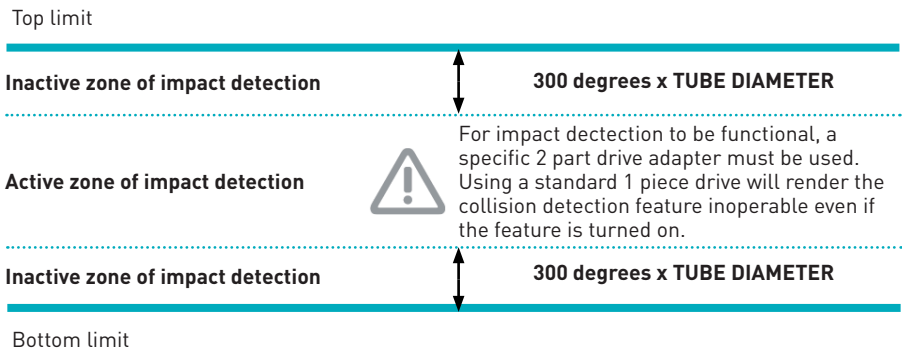

3 P1 BUTTON FUNCTIONS

3.1 Motor state test

This table describes the function of a short **P1** Button press/release (<2 seconds) depending on current motor configuration.

P1 Press	Condition	Function Achieved	Visual Feedback	Audible Feedback	Function Described
Short Press	If limit is NOT set	None	No Action	None	No Action
	If limits are set	Operational control of motor, run to limit. Stop if running	Motor Runs	None	Operational control of motor after pairing and limit setting is completed first time
	If motor is in "Sleep Mode" & limits are set	Wake and control	Motor wakes and runs in a direction	None	Motor is restored from Sleep Mode and RF control is active

3.2 Motor configuration options

The **P1** Button is utilized to administer motor configurations as described below.

Activate Pairing Mode

Approx. 2 SECS



Sleep Mode

Approx. 6 SECS



Reverse Direction

Approx. 10 SECS



Reset To Factory Settings

Approx. 14 SECS



Hold **P1** button on motor head.

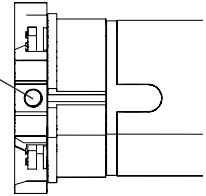

Factory settings include E-type mode and deactivate impact detection.

4 INITIAL SET UP

4.1 Pair motor with controller

Select channel on controller.



Hold **P1** button on motor head.

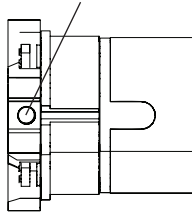

Hold **STOP** on controller.



IMPORTANT

Consult user manual for your controller for information on selecting channel.

Motor Response



Motor Response



Motor is now in step mode and ready for setting limits

4.2 Check motor direction

To check travel direction of shade, press **UP** or **DOWN** on controller.

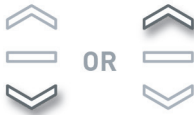

To reverse shade direction, hold both **UP** and **DOWN**.

Until the motor responds.



Quick Press = Step

Long Press = Continuous Travel

Motor Response



IMPORTANT

Damage to shade may occur when operating motor prior to setting limits. Attention should be given.

IMPORTANT

Reversing motor direction using this method is only possible during initial set-up

4.3 Set Upper Limit

IMPORTANT

Cycle shade up and down prior to setting limits to settle fabric

Move shade to the desired highest position by pressing the **UP** button on controller.

To save upper limit, hold **UP** and **STOP**.



Motor Response



4.4 Set Lower Limit

IMPORTANT (ULTRA-LOCK V2 ONLY)

When using the Ultra-lock, the bottom limit must be set within the 'locking zone'. Jog the weightbar down until you hear the locking pin click into the latch housing.

Once the bottom limit is set, refer to Section 10 to activate Fabric Tension Mode.

Move shade to the desired lowest position by pressing the **DOWN** button on controller.

To save lower limit, hold **DOWN** and **STOP**.



Motor Response



IMPORTANT

After setting limits, motor will automatically exit from initial set-up mode.

Initial set-up is complete

5 ADJUSTING LIMITS

5.1 Adjust upper limit

Hold **UP** and **STOP** on controller.



Move shade to the desired highest position by pressing the **UP** button.



To save upper limit, hold **UP** and **STOP**.



Motor Response



Motor Response



5.2 Adjust lower limit

Hold **DOWN** and **STOP** on controller.



Move shade to the desired lowest position by pressing the **DOWN** button.



To save lower limit, hold **DOWN** and **STOP**.



Motor Response



Motor Response



IMPORTANT (ULTRA-LOCK V2 ONLY)

When using the Ultra-lock V2, the bottom limit must be set within the 'locking zone'. Jog the weightbar down until you hear both locking pins click into each latch housing.

6 ADDING OR REMOVING CONTROLLERS AND CHANNELS

6.1 Using motor P1 Button to add a new controller or channel

Hold **P1** button on motor head.

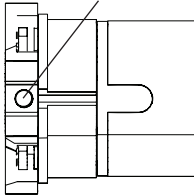

Hold **STOP** on controller to add. Motor keeps original limits.



Motor Response



Motor Response



6.2 Using a pre-existing controller to add or delete a controller or channel

A = Existing controller or channel (to keep)

B = Controller or channel to add or remove

Press **P2** on existing controller.

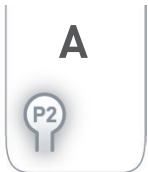

Press **P2** on existing controller.

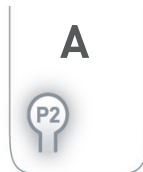

Press **P2** on an existing controller to remove it.

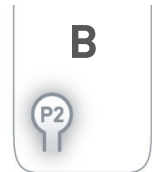

Motor Response



Motor Response



Motor Response



IMPORTANT

Consult user manual for your controller or sensor

7 FAVORITE POSITIONING

7.1 Set a favorite position

Move shade to the desired position by pressing the **UP** or **DOWN** button on the controller.



Press **P2** on controller.



Press **STOP** on controller.



Press **STOP** on controller.



Motor Response



Motor Response



Motor Response



7.2 Send shade to favorite position



7.3 Delete favorite position

Press **P2** on controller.



Press **STOP** on controller.



Press **STOP** on controller.



Motor Response



Motor Response



Motor Response



8 SLEEP MODE

If multiple motors are grouped on a single channel, Sleep Mode may be used to put all but 1 motor to sleep, allowing programming of just the one motor that remains "Awake".

Enter Sleep Mode

Sleep mode is utilized to prevent a motor from incorrect configuration during other motor setup.

Hold **P1** button on the motor head

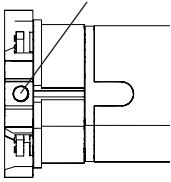

Motor Response



Exit Sleep Mode: Method 1

Exit sleep mode once the shade is ready.

Press and release **P1** button on the motor head

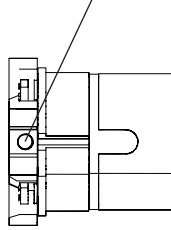

Motor Response



Exit Sleep Mode: Method 2

Remove power and then re-power the motor.

9 IMPACT DETECTION MODE

The Impact Detection feature only works in the active zone during downward movement (see Section 2.4).

All three modes have this impact detection feature deactivated by default (see Section 2.3).

Repeat sequence to turn on or off as required.

Press **P2** on controller.



Motor Response



Press **DOWN** on controller.



Motor Response



Press **DOWN** on controller.



Impact Detection ON

Motor Response



Impact Detection OFF

Motor Response



IMPORTANT

A 2 piece drive set must be used for impact detection to be functional. The use of a standard 1 part drive adapter renders the impact detection feature in-operable.

The top tube must be able to freely rotate - 5 degrees after installation.

10 FT FUNCTION SETTING

10.1 Activate / Deactivate Fabric Tension Mode

Note: When activating FT Mode for the first time, AUTOMATIC Lock Mode is selected.

Press **P2** on controller.



Press **UP** on controller.



Press **UP** on controller.



FT MODE:

Motor Response



NO FT MODE:

Motor Response



10.2 Switching between Auto & Manual Lock Mode

Note: Motor must be in FT mode before switching between lock modes.

Press **P2** on controller.



Press **STOP** on controller.



Press **DOWN** on controller.



AUTO MODE:

Motor Response



MANUAL MODE:

Motor Response



10.3 Auto Mode Operation

LOCK

Press **DOWN** on controller.



UNLOCK

Press **UP** on controller.

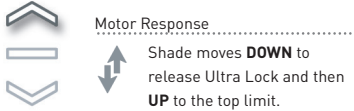

10.4 Manual Mode Operation

LOCK

Press **DOWN** on controller.

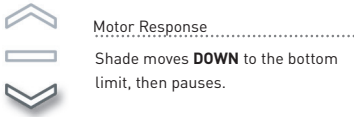

Press **UP** on controller.

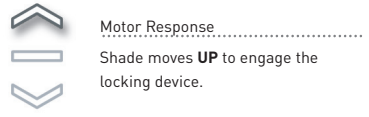

UNLOCK

Press **DOWN** on controller.

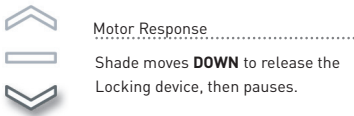

Press **UP** on controller.

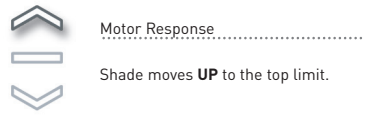

11 SUN, WIND AND RAIN SENSOR

Ensure the Sun, Wind and rain sensor functionality on the motor is activated prior to pairing the Sun, Wind and Rain sensor.

11.1 Activate/Deactivate Sun, Wind and Rain sensor functionality on the Motor

Note: Functionality activated by default.

PRESS **P2** ON CONTROLLER



Motor Response

.....



PRESS **UP** ON CONTROLLER



Motor Response

.....



PRESS **STOP** ON CONTROLLER



Motor Response (Activated)

.....



Motor Response (Deactivated)

.....



11.2 Pairing Sun, Wind and Rain sensor to Motor

ON REMOTE

PRESS **P2** ON CONTROLLER



Motor Response

.....



PRESS **P2** ON CONTROLLER



Motor Response

.....



ON SENSOR

PRESS **P2** TO WAKE THE SENSOR



PRESS **P2** ON AN EXISTING CONTROLLER TO ADD OR REMOVE IT.



Motor Response

.....



12 TROUBLE SHOOTING

Problem	Cause	Remedy
Motor is not responding	A/C power supply not plugged in.	Check motor to power cable connection and AC plug
	Transmitter battery is discharged	Replace battery
	Radio interference/shielding	Ensure transmitter is positioned away from metal objects and the aerial on motor or receiver is kept straight and away from metal
	Receiver distance is too far from transmitter	Move transmitter to a closer position
	Power failure	Check power supply to motor is connected and active
	Incorrect wiring	Check that wiring is connected correctly (refer to motor installation instructions)
Cannot program a single Motor (multiple motors respond)	Multiple motors are paired to the same channel	Always reserve an individual channel for programming functions
		SYSTEM BEST PRACTICE - Provide an extra 15 channel controller in your multi-motor projects, that provides individual control for each motor for programming purposes
		Place all other motors into sleep mode (refer to P1 button function overview - Section 3)

ROLLEASE ACMEDA | USA

200 Harvard Avenue
Stamford, CT 06902 6320
T +1 203 964 1573 | F +1 203 964 0513

ROLLEASE ACMEDA | AUSTRALIA

110 Northcorp Boulevard,
Broadmeadows VIC 3047
T +61 3 9355 0100 | F +61 3 9355 0110

ROLLEASE ACMEDA | EUROPE

Via Conca Del Naviglio 18, Milan
(Lombardia) Italy
T +39 02 8982 7317 | F +39 02 8982 7317

info@rolleasemed.com
rolleasemed.com